



UNI 50-3 WS

Compact carrier vehicle with interchangeable frame for various superstructures for use in underground mining

- Carrier with interchangeable system
- Payload of up to 10,000 kg
- Transport of various cassettes

Technical data

4415-00-000 - 18.04.2026

DEFINITION OF OPTION / OPTIONAL EQUIPMENT

13667-2

In the following, the selectable equipment of the machine is identified by the terms "option" or "optional equipment."

The option describes equipment that can be selected in addition to the standard machine.

The optional equipment describes equipment that replaces other equipment on the machine.

- Travel drive gear shift in neutral position
- Parking brake is activated
- Steering is deactivated

KEY FEATURES OF THE MACHINE

13187-2

Compact carrier vehicle with interchangeable frame for various superstructures for use in underground mining

SAFETY

13369-4

All machines are designed and manufactured in accordance with the applicable legal requirements. They offer a correspondingly high level of safety for users.

Some safety features at a glance:

- ROPS/FOPS protective canopy
- Battery main switch, lockable
- Emergency stop button: one in the driver's cab, two outside
- Automatic shutdown when engine-specific parameters are exceeded
- Audible reverse signal
- 3-point safety entry
- Non-slip and color-contrasting entrances and exits
- Articulation lock
- Connector protected against moisture
- Brake test function

In the event of operator absence, the following happens automatically if the door contact switch is activated:

OPERATING CONDITIONS

12998-5

Permitted ambient temperature * -20 °C to +40 °C

* *Observe the cold start limit temperature of the engine*

Permitted longitudinal inclination, maximum 35 %

Operating height without power reduction, maximum < 1,500 m

WEIGHTS AND LOADS

13292-2

Operating weight * 9,000 kg

Permitted payload, maximum * 10,000 kg

Permitted front axle load, maximum 8,000 kg

Permitted rear axle load, maximum 11,000 kg

* *Depends on selected options and optional equipment*

CHASSIS

13293-1

Articulation angle, maximum ±10°

- Split chassis with articulated steering
- Fixed front axle and oscillating rear axle

ENGINE

13296-4

DEUTZ TCD 2013 L04 2V diesel engine

Manufacturer DEUTZ

Technical data

4415-00-000 - 18.04.2026

Type	TCD 2013 L04 2V
Emission standard EU	Stage III A
Emission standard USA	EPA Tier 3
Output At speed	126 kW 2,300 rpm
Alternator	28 V 80 A
Starter motor	24 V 4 kW
Cold start limit temperature	-15 °C

- Catalytic converter with measuring points
- Fuel prefilter and fuel fine filter with water separator
- Manual fuel feed pump
- Dry air filter with pre-separator
- Liquid-cooled

13306-5

ENGINE (OPTIONAL EQUIPMENT)

Diesel engine CATERPILLAR C4.4

Manufacturer	CATERPILLAR
Type	C4.4
Emission standard EU	Stage III A
Emission standard USA	EPA Tier 3
Output At speed	106 kW 2,200 rpm
Alternator	28 V 60 A
Starter motor	24 V 4.5 kW
Cold start limit temperature	-15 °C

- Catalytic converter with measuring points
- Fuel prefilter and fuel fine filter with water separator
- Dry air filter with pre-separator
- Liquid-cooled

Diesel engine DEUTZ TCD 4.1 L4

Manufacturer	DEUTZ
Type	TCD 4.1 L4
Emission standard EU	Stage V
Emission standard USA	EPA Tier 4F
Output At speed	105 kW 2,300 rpm
Alternator	28 V 100 A
Starter motor	24 V 4 kW
Exhaust after-treatment	DOC DPF SCR
Cold start limit temperature	-15 °C

- Fuel prefilter and fuel fine filter with water separator
- Dry air filter with pre-separator
- Liquid-cooled

13307-1

FUEL SYSTEM

Fuel tank capacity	125 L
<ul style="list-style-type: none"> ■ Electric level indicator ■ Shut-off valve to prevent fuel leakage in the event of a hose breakage 	

13311-1

DRIVE

Manufacturer	DANA
Type	24300
Travel speed:	
1st gear	5 km/h
2nd gear	10 km/h
3rd gear	25 km/h

Technical data

4415-00-000 - 18.04.2026

Tractive force (loaded):

1st gear	130 kN
2nd gear	60 kN
3rd gear	26 kN

Climbing power (loaded):

1st gear	97 %
2nd gear	34 %
3rd gear	14 %

- Hydrodynamic travel drive
- "Full power shift" transmission
- Three forward and reverse gears
- Single-stage torque converter
- Drive reversible under load
- Continuous all-wheel drive

AXES

13315-1

Manufacturer	DANA
Front axle type	113
Front axle differential	Open
Rear axle type	113
Rear axle differential	Open

SERVICE BRAKE

11330-3

- Hydraulic foot brake as 2-circuit external force brake system
- Wet brake in oil bath

PARKING BRAKE

11332-1

- Spring tensioned, hydraulically released (SAHR)
- Manual pump to release the brake in case of system failure

EMERGENCY BRAKE

13234-1

- The parking brake also acts as an auxiliary brake

TIRES

13323-1

Tire size	12.00x20
Tire filling	Air

- Single tires with inner tube

TIRES (OPTIONAL EQUIPMENT)

13325-1

Tire size	12.00x20
Tire filling	Air

- Single tires without inner tube

STEERING

13318-1

- Hydraulic articulated steering with two double-acting hydraulic cylinders
- Steering wheel steering
- Emergency steering

HYDRAULICS

13321-1

Hydraulic tank capacity	130 l
-------------------------	-------

- Inspection gauges for min/max level display
- Temperature sensor
- Electrical fill level monitoring
- All fittings as JIC version

Technical data

4415-00-000 - 18.04.2026

HYDRAULICS (OPTIONAL)

13376-1

* Maximum of two lights possible

- Manual pump for filling the hydraulic fluid reservoir
- Electric pump for filling the hydraulic fluid reservoir

ELECTRICAL SYSTEM

13237-1

Operating voltage	24 V
Number of batteries	2 pcs.
Battery voltage	12 V
Battery charge	155 Ah

ELECTRICAL SYSTEM (OPTIONAL)

12822-3

- Jump start socket
- Enhanced sealing of the connectors with grease filling and sealing tape

LIGHTING

13326-2

All headlights and lights as LED variants:

- Two main headlights at the front, with high beam, low beam, parking light and turn signals
- Two working lights at the rear of the cabin
- Two tail lights with tail light, brake light, reversing light and turn signals
- Two additional reversing lights
- One yellow flashing light

LIGHTING (OPTIONAL)

13375-2

- Direction indicators red / green, front / rear
- Two impact lights in the articulated joint area
- Two additional working lights on the front of the cabin
- Blue rotating flashing beacon / flashing lights *
- Red rotating flashing beacon / flashing light *

CAB

13329-7

Driver's seat and passenger seat

- Lap belt
- Vinyl cover
- Adjustable backrest and seat surface
- Height adjustable
- Mechanical suspension

Open cabin

- Open cabin with half doors
- Exit on both sides
- Storage under the passenger seat
- Windshield made of laminated safety glass
- Wiper/washer system for windshield
- Interior lighting
- Reading light
- Ventilation for windshield
- Two mirrors
- Document box
- All drive relevant switches, displays and operations are located within reach of the operator
- Information display for all engine-specific data

DRIVER'S CAB (OPTIONAL EQUIPMENT)

13353-6

- Mechanically sprung seats for driver and passenger with 3-point harness and seatbelt monitoring
- Air-sprung seats for driver and passenger with 3-point harness and seatbelt monitoring
- Heated exterior mirrors
- WEBASTO water heater

Rotating driver's seat

- Rotates 90° for better rear view
- Brake pedal, accelerator pedal and gear shifting controls are also rotated
- Mechanical locking mechanism

Enclosed cabin

- Enclosed cabin with doors and sliding windows
- Exit on both sides
- Storage under the passenger seat
- Windshield made of laminated safety glass
- Wiper/washer system for windshield
- Interior lighting
- Reading light
- Heater with ventilation and filter
- Two mirrors
- Document box
- All drive relevant switches, displays and operations are located within reach of the operator
- Information display for all engine-specific data

DRIVER'S CAB(OPTIONAL)

13354-5

- Air conditioning system
- Rearview camera system or 4-camera system
- Vandalism protection
- Activation of the parking brake when the travel drive is in the neutral position for longer than 3-4 seconds
- Tire pressure monitoring
- Dead man's switch for driving mode
- Electric emergency steering
- Engine start warning
- Holder for self-rescuer
- Second passenger seat *

* Not possible with rotating driver's seat

Radio preparation

- Ignition voltage
- Battery voltage
- Vehicle mass

CAN bus interface preparation

- Ignition voltage
- Battery voltage
- Vehicle mass
- CAN High
- CAN Low

SUPERSTRUCTURE

13361-2

Interchangeable system

- Hydraulically driven lifting frame
- Integrated in the rear vehicle frame
- For lifting and changing various PAUS interchangeable cassettes
- Quick release for the secure attachment of various interchangeable cassettes
- User-friendly changing process without additional aids

Hydraulic and electrical supply for the superstructures

Power at 220 bar and 50 l/min, maximum 20 kW

- Open circuit
- Can only be used in working mode

SUPERSTRUCTURE (OPTIONAL EQUIPMENT)

13362-2

High-performance hydraulic supply for the superstructures

Power at 220 bar and 140 l/min, maximum 50 kW

- Open circuit

High-performance hydraulic supply for the superstructures

Power at 280 bar and 115 l/min, maximum 55 kW

- Closed circuit

Technical data

4415-00-000 - 18.04.2026

WORK EQUIPMENT (OPTIONAL) 13363-2

- Pressure washer with 70 l water tank *
- Compressor type HK450 *
- Welding machine type HWG 180 *
- Welding machine type HWG 400 *

** Maximum of two options possible*

Front supports

- Hydraulic telescopic support
- Right and left, fixed mounted on the front end
- Vertically extending
- Lowering brake valves in the hydraulic cylinders

FIRE PROTECTION 12818-6

- Handheld fire extinguisher

FIRE PROTECTION (OPTIONAL EQUIPMENT) 12993-3

- HRD fire suppression system (PROTECFIRE) with manual trigger and dry chemical extinguishing agent
- HRD fire suppression system (PROTECFIRE) with automatic trigger and dry chemical extinguishing agent
- HRD fire suppression system (ANSUL) with manual trigger and wet agent solution
- HRD fire suppression system (ANSUL) with automatic trigger and wet agent solution
- Portable fire extinguisher (ANSUL) with 7.7 kg of dry chemical extinguishing agent

FIRE PROTECTION (OPTIONAL) 13365-1

- Additional handheld fire extinguishers

** Type depends on the handheld fire extinguisher selected*

PAINTWORK 13366-1

Color of cabin / driver's cab	RAL 7016
Chassis color	RAL 1007

ACCESSORIES 12249-5

- Two wheel chocks
- Two hazard warning triangles
- Tool bag
- Safety helmet and hearing protection
- First aid kit

ACCESSORIES (OPTIONAL) 13368-1

- Spare rim
- Spare tire
- Expanded tool kit
- Central lubrication system on basic vehicle
- Deflector for windshield and mirror as tubular construction

DOCUMENTATION 11344-3

- A printed operating manual in the local language in the document box
- Operating manual, spare parts list and circuit diagrams in electronic form via online access

DOCUMENTATION (OPTIONAL) 12825-4

- An additional operating manual in local language, in printed form, included with the machine
- A spare parts list in local language or English, in printed form

MAINTENANCE KITS (OPTIONAL EQUIPMENT)

12824-3

- Service package, 2000 operating hours
- Service package, 3000 operating hours
- Service package, 5000 operating hours

PAUS CONNECT CLOUD (OPTIONAL)

11355-8



The PAUS CONNECT CLOUD collects and visualizes data, messages or location information of the machine.

The data is transmitted to the cloud using a built-in telemetry unit.

Your advantages:

- Faster service
- Lifecycle cost management
- Data transmission via existing wi-fi and/or cellular networks
- Data buffering of all data in case of no connectivity (up to 30 days)
- Access to the PAUS CONNECT CLOUD
- Remote diagnostics/remote maintenance
- Statistical usage analysis
- Vibration monitoring
- Individual evaluation and statistics

CUSTOMER SERVICE

11353-2

Repair work and maintenance work are central points in customer support. Here, PAUS is broadly positioned and offers its customers and dealers worldwide an extensive service program. Trained employees are available on our service hotline, as are competent contact persons at our local dealers.

SPARE PARTS

11354-2

We attach great importance to a high level of availability of PAUS spare parts. In addition to maintenance and service parts, which are available at any time, customers and dealers are able to purchase spare parts for engines, axles, transmissions, etc. easily and quickly through us. Benefit from our on-line catalog with refined spare parts lists.

Technical data

4415-00-000 - 18.04.2026

DIMENSIONS

10716-3

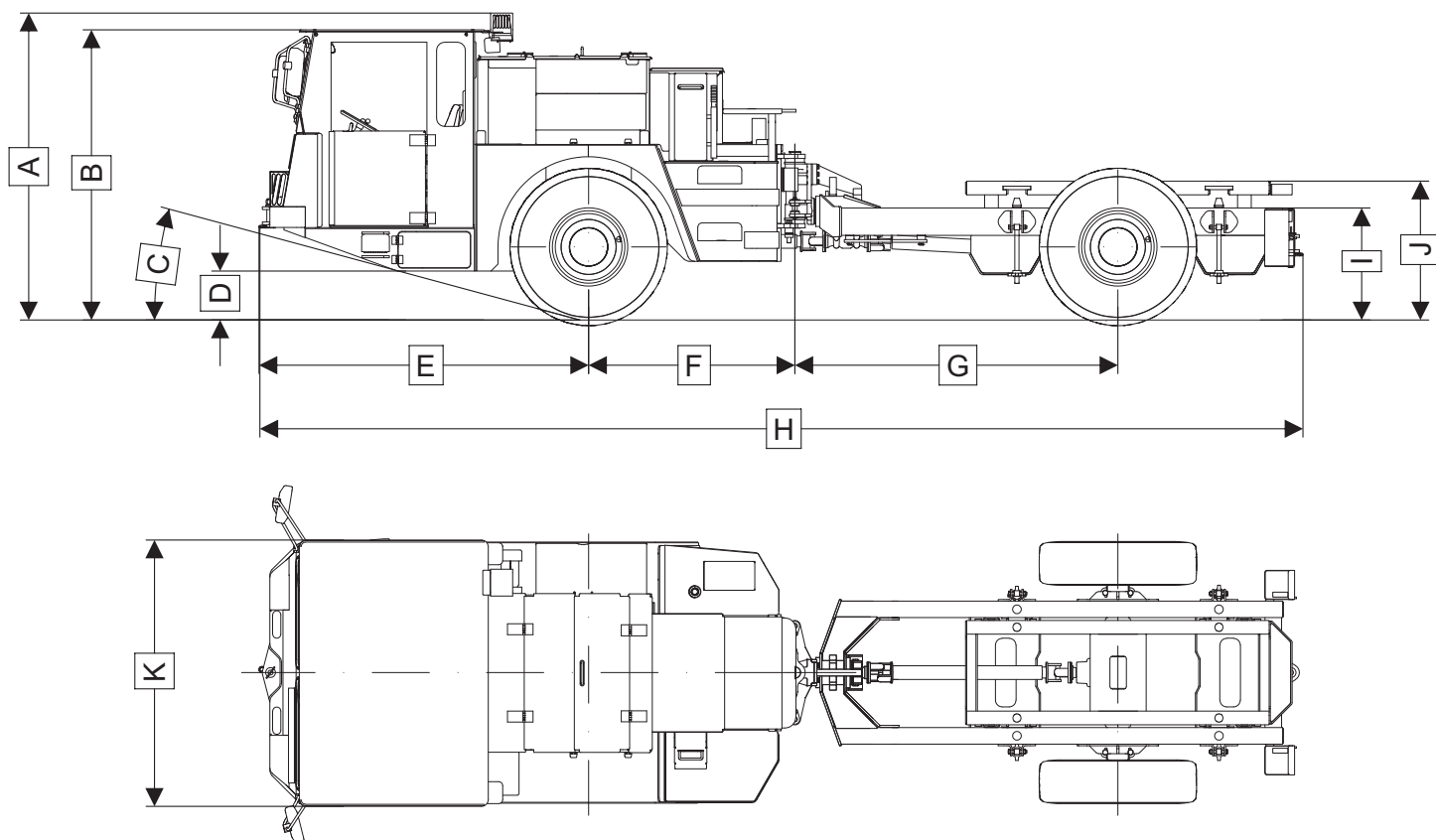

388311-00

The illustration may differ from the scope of delivery

Dimension	Value	Unit
A	2,260	mm
B	2,140	mm
C	15	°
D	350	mm
E	2,380	mm
F	1,500	mm
G	2,350	mm
H	7,550	mm

Technical data

4415-00-000 - 18.04.2026

Dimension	Value	Unit
I	825	mm
J	1,015	mm
K	1,900	mm

TURNING RADII

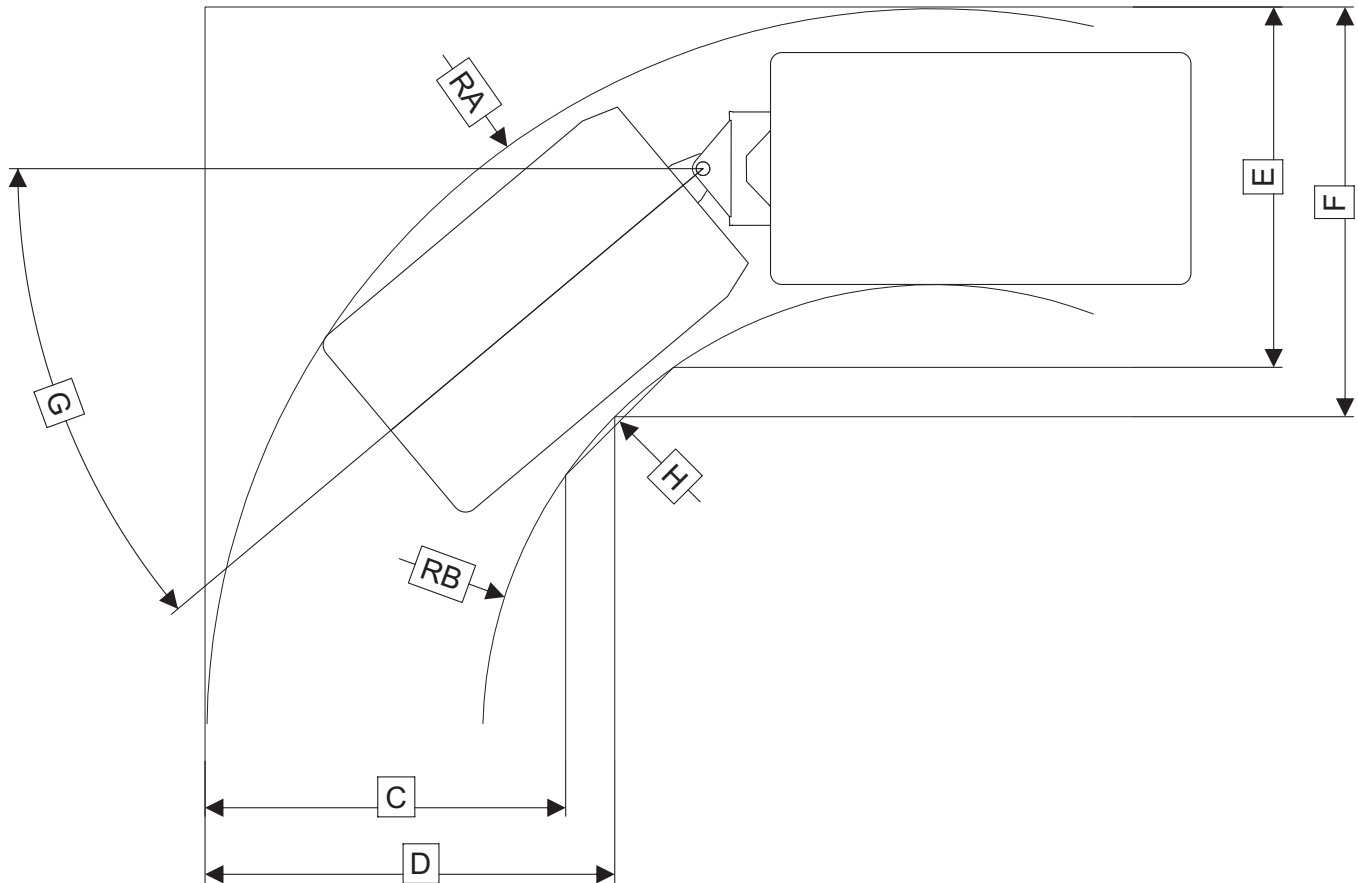

The illustration may differ from the scope of delivery

Dimension	Note	Value	Unit
RA		6,750	mm
RB		4,150	mm
C		3,350	mm
D		3,800	mm
E		3,350	mm
F		3,800	mm
G	Steering angle, maximum	40	°
H	Beveled corner	1,000x45°	mm